

The flexible build plate component of Creator Pro 2

Creator Pro 2 offers two options of build plate

A: Aluminum platform

As a default.

B: The flexible build plate

The flexible build plate component of Creator Pro 2 Include: magnetic plate, spring steel plate, blue build tape. Printing on the flexible steel build plate, which is more convenient to remove the model.

The flexible components are installed as follows

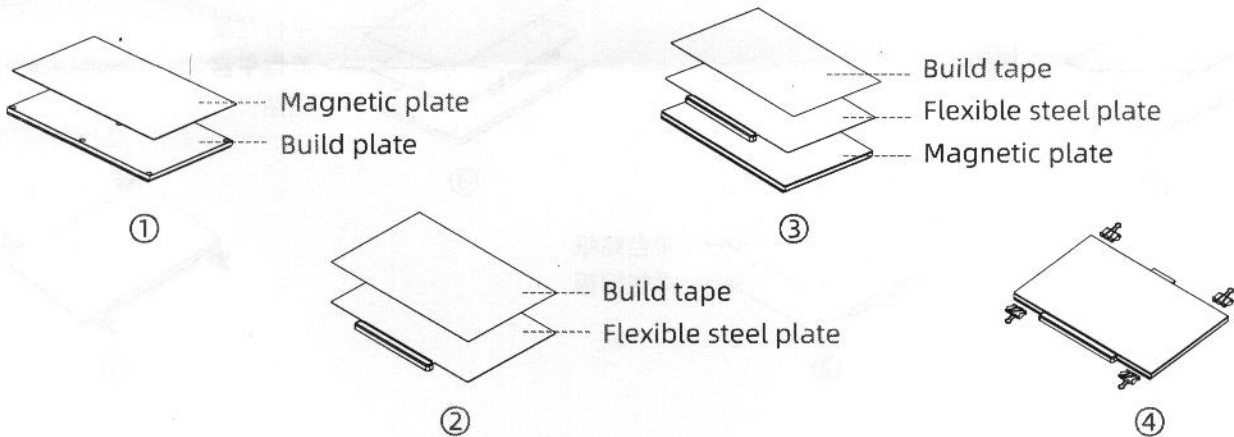

1. Please make sure the build plate is clean and tidy. Tear off the parting paper on the back of the magnetic plate and attach the magnetic plate to the build plate.
2. Attach the build tape to the spring steel plate (Ignore if it is already attached).
3. Place the flexible steel plate on the magnetic tape and pay attention to whether it fits smoothly.
4. When printing a large model or the temperature of the platform is above 70 degrees, please use 4 clips to clamp the steel plate and the platform holder to prevent warping in the printing process.

Note: the clamp is needed to prevent warping for the reason that the magnetism of the flexible magnet will be weakened under the condition of high temperature.